



2022+ Toyota Tundra sPOD Kit Instructions 87-0089, 87-0090, 87-0091



2950 Norman Strasse Rd. • San Marcos • CA • 92069

Phone 661-775-7799 • Fax 760-560-0383

tech@4x4s-pod.com • www.4x4spod.com



Warranty & Returns Policy

WARRANTY AND REPAIR POLICY

sPOD offers a non-transferable 5-year limited warranty on electronic parts and components from manufacturers defects from the date of purchase (Effective on products purchased after 4/1/23). sPOD will repair or replace items in question and return them to Buyer at no charge. If the identical product is no longer available, sPOD will replace with a similar product of equal value. sPOD will not be responsible for any indirect or consequential damages in connection with defective merchandise.

Exclusions:

Products that have been subjected to abuse, misuse, accident, alteration, modification, improper installation, tampering, or any use other than the product's designed purpose will void the warranty. The sPOD warranty excludes the following: Installation errors, abuse, misuse or crash damage, reverse polarity of battery cables, changing the 2 amp fuse for any other rated fuse, cutting off our connectors, splicing into our wires/harnesses, attaching anything other than our battery cables to our positive and negative terminal studs on our BantamX/SourceLT boards, changing our supplied switches (switch body), removing the actuators without using our specific actuator removal tool. This warranty shall be automatically voided if the items sent for warranty replacement are modified in any way or were not used as intended or applicable. Additionally, this warranty excludes normal wear and tear. NOTE: Any or all aftermarket brake controllers, hi-amp solenoids or any hi-amp relay that is attached to the same positive battery post will cause irreversible damage to the sPOD system. This will void all warranties. This warranty shall be automatically voided if the items sent for warranty replacement are returned with water/liquid/chemical damage to any electrical component.

The buyer MUST provide a copy of the original invoice or have completed the online product registration. Shipping responsibilities and/or charges will be determined once a claim has been opened. sPOD systems will be repaired or replaced at manufacturer's discretion. This warranty does not cover miscellaneous expenses, including, but not limited to, outside labor costs incurred for the installation, removal, replacement, and repair or troubleshooting. **Please contact sPOD to assist with troubleshooting prior to uninstalling your entire system as the solution may not require that the system be removed.**

All claims must be made in writing by mail or e-mail directly to sPOD:

By Mail: sPOD 2950 Norman Strasse Road San Marcos, CA 92069

By E-mail: Tech@4x4s-pod.com



RETURN AND REFUND POLICY

sPOD will accept returns within 30 days from receipt of merchandise under the following conditions:

Merchandise needs to be returned unused, with all printed material and accessories enclosed. If not in its original condition or the product shows signs of installation, additional charges will be applied or may not be accepted. All returns must be accompanied with a return merchandise authorization (RMA) number (to be provided by sPOD at time of request) and a receipt of original purchase.

To obtain an RMA number, please email Tech@4x4S-pod.com with your full name, invoice number, and part number of the item(s) you need to return.

A 15% percent restocking fee will apply after 30 days. All shipping charges are at the buyer's expense. The original shipping fees are non-refundable. We strongly recommend you insure all packages before shipping. We are not responsible for lost or stolen merchandise while in transit. We assume liability once the returned system has reached our facilities.

Once your return shipment has been received and approved, your return will be processed.

Failure to comply with the process and terms stated above may result in a processing delay and/or a refusal of the returned package.

The above warranties and policies are subject to change without prior notice.

Tools Required

- Trim tool and Sm. Flathead or pick
- 3mm and 2.5mm Allen Key
- Phillip's Head
- 12mm wrench
- 10mm, ½", 7/16" Sockets
- 0.25", 0.75" Drill or Step Drill

To begin, make sure the vehicle is in park, on level ground and the parking brake is engaged.

1. Disconnect battery ground.

Gently pull down from the edge nearest the windshield until the upper console is free.

2. Carefully press in on the locking tab of the electrical connector to release it from the upper console. Place console assembly onto a soft work surface.



3. Use the flathead screwdriver and pry tool to release the six tabs shown (3a), while applying pulling pressure to the trim panel (arrowed in 3b).

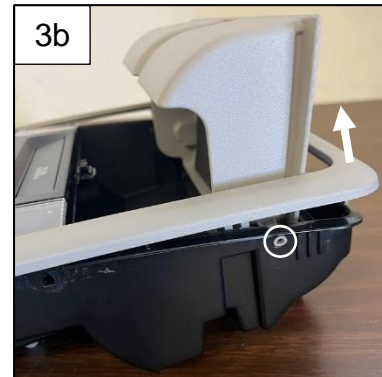
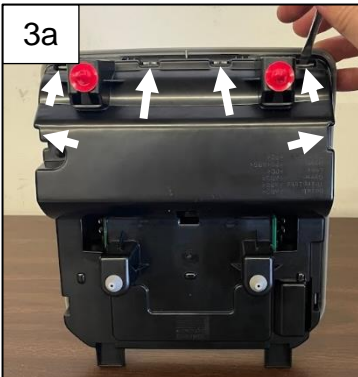

4. With the flathead screwdriver, press in on the sunglass holder pivot (circled in step 3b) and pull on the side wall until it is free. Twist the holder until it can be removed. Place aside, it will not be reused.

5. Cut out provided stencil and place into console. Mark and drill two 0.25" holes.



6. With the 0.75" drill, make a hole in the location shown for the short ethernet cable passthrough.

7. Assemble the provided panel to the underlying overhead mounting bracket as shown using the 2.5mm Allen wrench and provided flathead hardware.

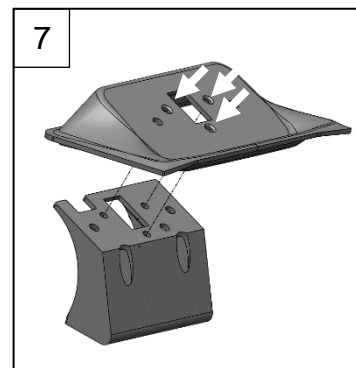
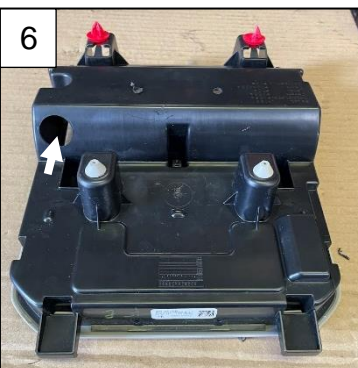

8. Mount the sPOD switch assembly to the panel with the logo on the side as shown (asterisk) and tighten the nuts with the 7/16" socket.

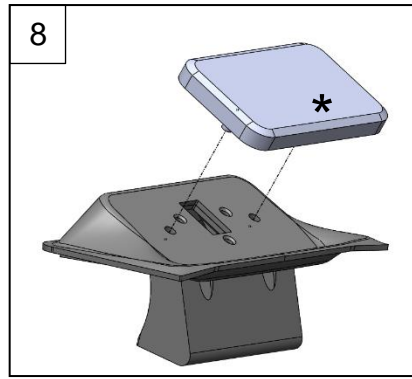

9. Route the small ethernet cable through the hole from step 6 and plug it into the Tundra sPOD switch panel assembly. With the provided socket head hardware, washers, and 3mm Allen wrench, tighten the assembly into the console through the holes from step 5 (arrowed).



10. Route the long ethernet cable from the upper console area out through the front edge of the headliner. Pull slack, attach the long cable to the small cable, plug in upper console and reinstall.

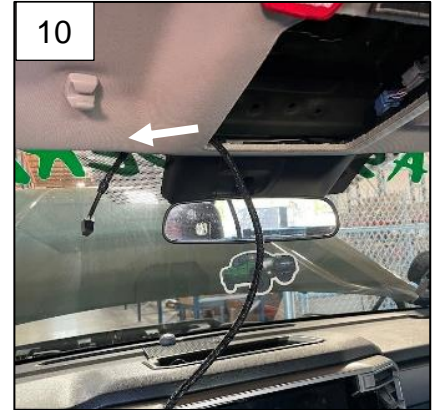

11. Gently squeeze the two caps on the driver-side A Pillar handle to remove. Using the 10mm socket, remove the two circled bolts.



12. Carefully pull until the A Pillar panel releases. Tuck the ethernet cable along the headliner and route down the A Pillar. **Do not wrap around the airbag.**



13. Pull the side panel on the driver side end of the dash and remove. Route the ethernet cable from the base of the A Pillar, down to the footwell.



14. Pull the door seal weatherstripping down from the forward top half of the door opening.



15. Gently pull up on the door sill trim until the four clips release (circled). Place aside.

16. Remove the arrowed thumb screw at the top left edge of the dead pedal. Pull the panel toward the back of the vehicle to remove and place aside.



17. Locate the firewall passthrough in the driver side footwell (arrow). Pull back the insulation and pull the harness grommet into the cab. Route the cable through into the engine compartment. It is recommended to remove the OEM harness tape, snake the wire through, and retape. There is also a hole that may be punctured.

18. From the engine compartment side, pull the grommet and reestablish the seal. (Vaseline, or dielectric grease may be used)

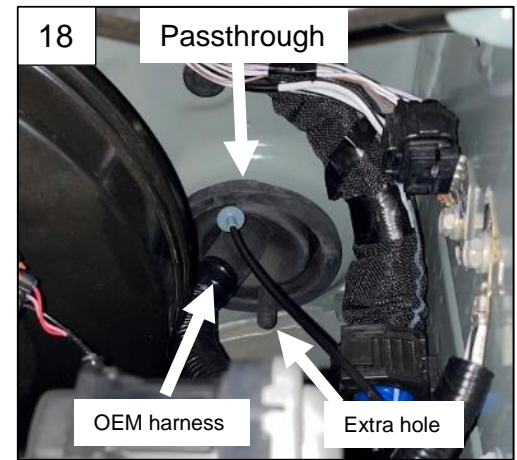

19. Locate the two circled bolts on the driver side inner fender next to the ABS pump. Loosen both halfway with the 12mm wrench (approx. 0.25" threads exposed).

20. Place the PCM bracket assembly over the loose bolts from step 19 and tighten. Remove PCM lid, Plug in ethernet and replace lid.

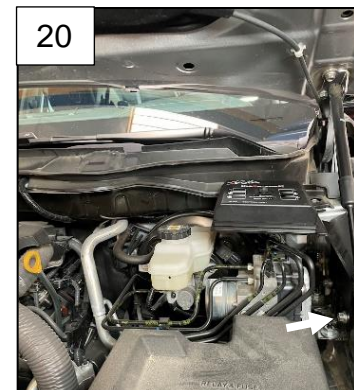
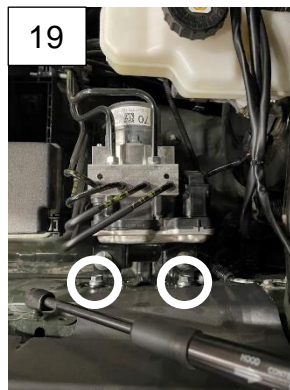

21. Route battery cables across the firewall and attach the battery positive. Zip tie cables against the firewall. Attach the sPOD and OEM negative cables to the battery.

22. Perform steps 16-11 in reverse order, leaving the door weather seal until last.

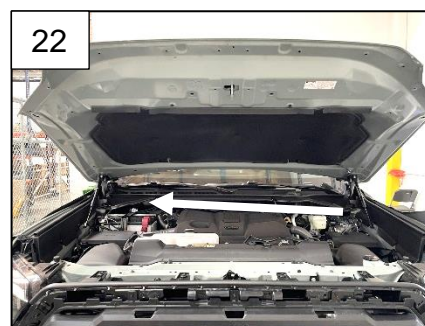

*Tie all wires away from sharp, hot, and/or rotating components.

* Re-torque all the fasteners after 100 miles. Start engine to initialize and reference sPOD hardware instructions for setup.

*Your install is now complete! Thank you for choosing sPOD.

