



**baja designs**<sup>®</sup>  
THE SCIENTISTS OF LIGHTING

**2022 Toyota Tundra Dual Squadron 2.0 Vent Kit  
44-0077, 44-0078**



2950 Norman Strasse Rd. • San Marcos • CA • 92069

Phone 760-560-2252 • Fax 760-560-0383

info@bajadesigns.com • [www.bajadesigns.com](http://www.bajadesigns.com)



**baja designs**<sup>®</sup>  
THE SCIENTISTS OF LIGHTING

## LIMITED LIFETIME WARRANTY

Baja Designs proudly offers a LIFETIME WARRANTY against manufacturer's defect on all the products that we manufacture.

These are comprehensive warranties; other than the exclusions below – you're covered. If your LED or HID bulb burns out, you're covered. Additionally, cutting off our connector or changing your lenses does not automatically void your warranty.

### **Exclusions:**

Installation errors, abuse, misuse or crash damage. You must be the original owner of the product and can supply proof of purchase.

Baja Designs manufactures its own products as well as resells products manufactured by others. Baja Designs makes no express or implied warranties on products not manufactured by Baja Designs including without limitation any warranties or merchantability and fitness for a purpose. We will, however, pass on all warranties made by the manufacturer, who has sole responsibility for performing such warranties.

Baja Designs will pay the freight if your product is less than 90 days old, otherwise defective products must be returned to Baja Designs, Inc., freight prepaid. At our option, we will repair or replace items in question and return them at no charge. If the identical product is no longer available, we will replace with a similar product of equal value. Baja Designs Inc. will not be responsible for any indirect or consequential damages in connection with defective merchandise.

Items purchased through a Baja Designs authorized dealer must be returned through the dealer. Only available on LED auxiliary lights and product must be in sellable condition at MSRP. Product that has been damaged in any way after the original purchase date will be excluded from this guarantee.

### **Indemnification:**

**Buyer hereby acknowledges off-roading, racing and driving at night are dangerous activities and that the products and/or supplies purchased from Baja Designs are used in an inherently dangerous activity that may endanger life and limb; and in no event shall the seller, or seller's heirs and assigns, be held liable for consequential damages, nor shall seller's liability on any claim for damages arising out of or connected with the sale, delivery, or use of purchased products and/or supplies exceed the purchase price of the products and/or supplies.**

**Buyer is responsible for ensuring that it uses the products (and its vehicle) in accordance with all applicable laws, regulations, guidelines, and standards of care. Buyer acknowledges that some products may only be used when off-roading, and Buyer will comply with all vehicle and road safety guidelines. Buyer is solely responsible for (and will indemnify and hold Bestop harmless for) any claims, losses, damages, fines, fees, costs, or other amounts arising out of Buyer's non-compliance with these provisions.**

## **Tools Required**

- |                            |                     |                         |                 |
|----------------------------|---------------------|-------------------------|-----------------|
| * 10mm, 12mm, 7/16" socket | *3/4" drill bit     | *Snips, or wire cutters | *Scissors       |
| *Phillips head screwdriver | * Trim removal tool | *Flathead screwdriver   | *5/32 Allen key |

**To begin, make sure the vehicle is in park, on level ground and the parking brake is engaged.**

1. Using a 10mm socket, remove the 5 frontmost screws from the driver side inner wheel well to release the front edge of the fender flare (1a). Carefully pull the front of the fender flare away from the fender until the clips release up to near the back of the headlight (1b).

2. Repeat step 1 for the passenger side of the vehicle.

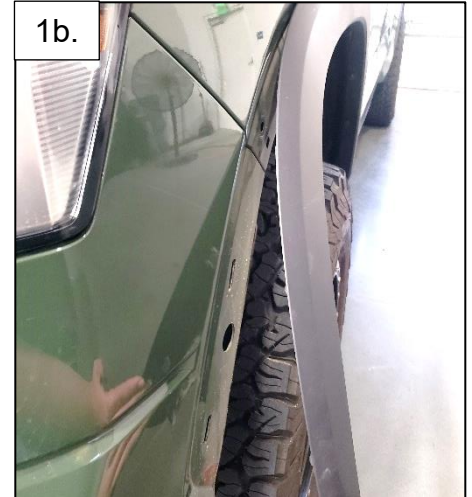
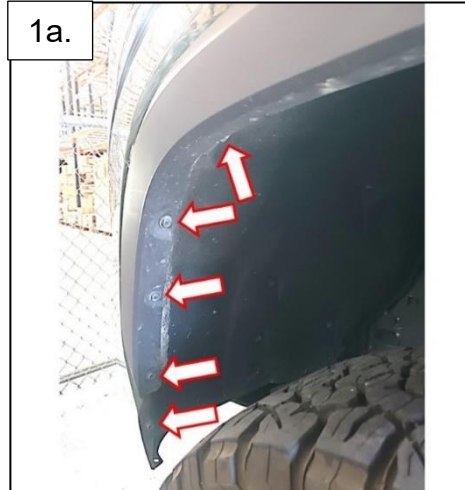

3. Using a 10mm socket, remove the 4 bolts securing the lower bumper assembly.

4. Using a 10mm socket, remove the 4 bolts securing the upper grill.

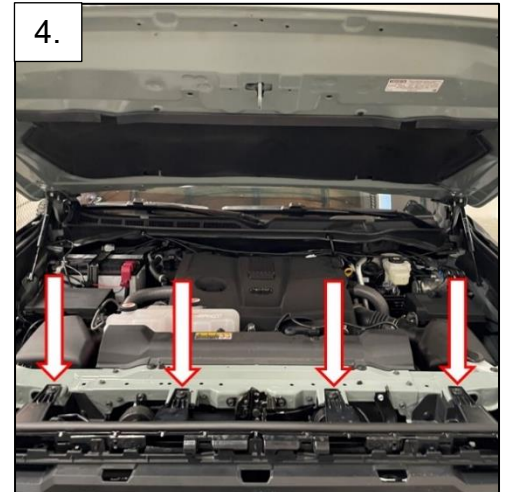
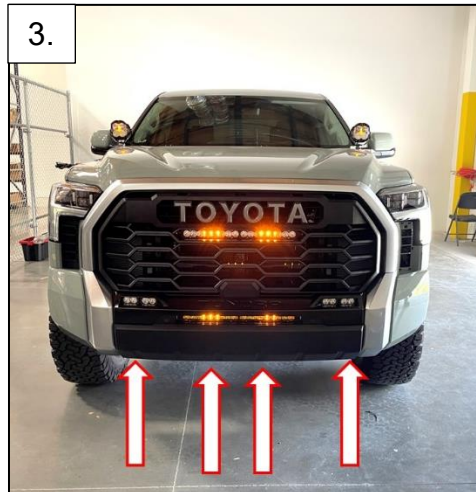

5. Disconnect the electrical connectors on the top of the grill near the top of the radiator (arrowed). For TRD models, there are two on the driver side and two on the passenger side. For non-TRD models, there are two on the passenger side and one on the driver side.

6. Using a trim tool or flathead screwdriver, remove the 2 plastic push rivets from either side of the grill near the previously disconnected electrical connectors.



7. Starting from inside the driver side fender well, carefully pull the front corner panel sideways (a) and forward (b) to release all the clips under the headlight and grill vent. Repeat for the passenger side.

8. With the help of an assistant, carefully remove the front clip of the vehicle by pulling forward and set it on a soft work surface. There are three clamping features that will release with a light tug and an audible click (squared). Using the trim tool, remove the plastic vent covers by releasing the tabs from the back of the front clip (dashed rectangle regions).

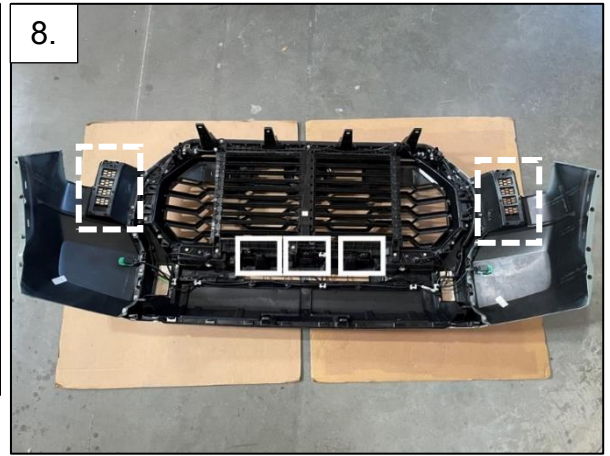
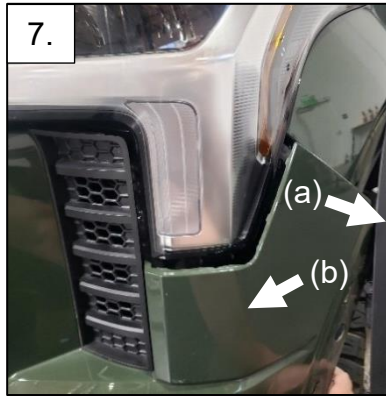

9. With snips, cut either side of the plastic piece spanning the opening in the two circled locations pictured on the front clip and discard.

10. Locate the crash attenuator located underneath the driver side headlight. The provided clip-on nuts will be applied into both circled holes.

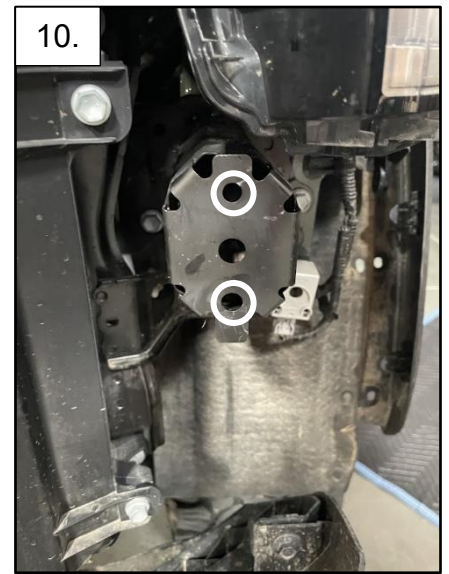

11. Using a flathead screwdriver, gently pry the top and/or bottom attenuator edges to allow the clip-on nuts to slide into position. Then use the screwdriver to press them back into their original position.

12. Install the vent kit mounting bracket with the provided hex head bolts and washers, using a 7/16" socket. Repeat steps 9-12 for the passenger side.

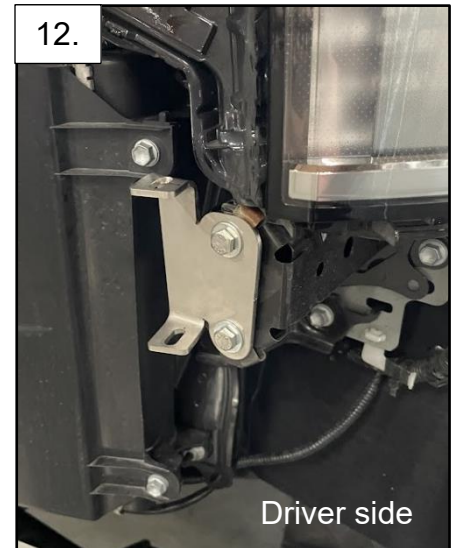
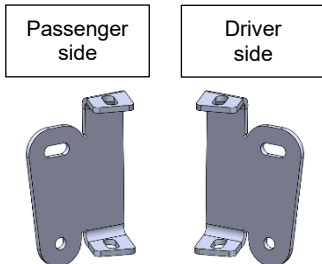

13. **Before** installing the front clip, route the wiring harness (64-0055) along the inner bumper to the lights.  
 14. With the help of an assistant, reinstall the front clip ensuring that the 3 tabs (boxed in photo 8) lock into place. Replace the 2 plastic push rivets on the top of the grill (Arrowed).

15. Snap in the driver side outer fenders starting near the headlight and moving outward (Step 7 in reverse). Repeat on the passenger side of the vehicle.

16. With the provided EPDM rubber, cut pieces (2x 4") and remove the adhesive backing. Place one piece on the bottom of the fascia bracket so the rubber is halfway on each side of the corner (Driver side shown). For the second piece of rubber, place the piece as shown on the top of the bracket and round it over the bent corner approximately 0.5". Use relief cuts and trim as needed. Repeat for the passenger side.

17. Locate the driver side bracket and Squadron 2.0 lights that have the fins oriented as shown. The power cords will route through the bracket. Mount each light to the bracket using a 10mm socket to tighten the provided 6mm light bolts with washers.

18. Place the clip-on nut onto the L-brackets with the threaded portions facing into the inside corner. There is a slot to adjust the nut as needed. With a 10mm socket, install the L-brackets onto the vent kit mounting bracket as shown with the provided bolts and washers threaded through the long side of the L-bracket. Leave them just loose enough to slide the bracket for now.

19. The power cords will need to be routed through the vent opening and downward. Using a Phillip's screwdriver (Later kits, 5/32" Allen) and the provided black flathead hardware, install the driver side light assembly onto the vent kit mounting bracket holes (circled). Adjust the lights and vent bracket, then remove the light assembly. Tighten the bolts from step 16-17. Reinstall the lights. Repeat for the Passenger side (16-18).

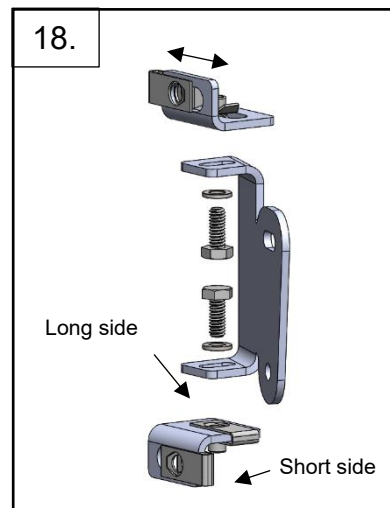
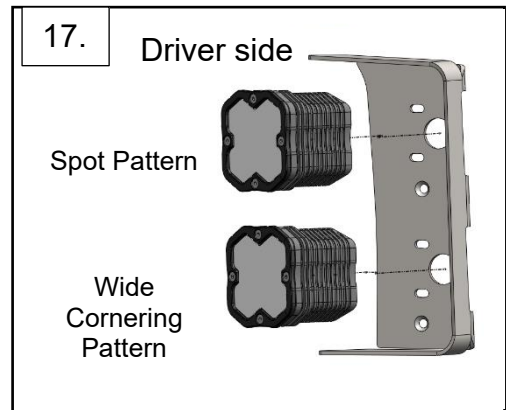
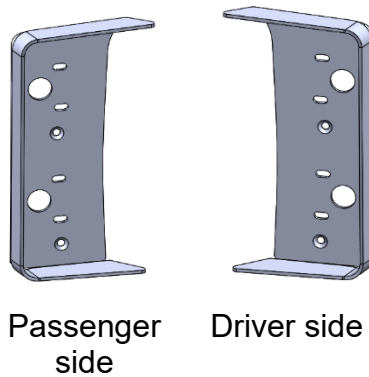
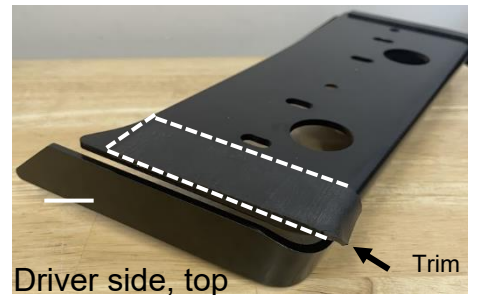
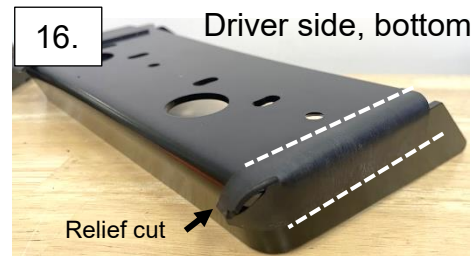
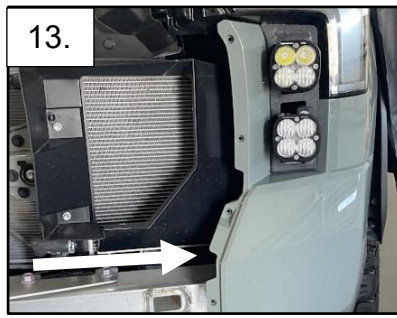

20. Locate the included wiring harness previously routed, and mount the relay to the common ground located next to the passenger side air box using the mounting tab on the relay.

21. Run the switch lead along the firewall and to the wiring passthrough located to the right of the brake master cylinder.

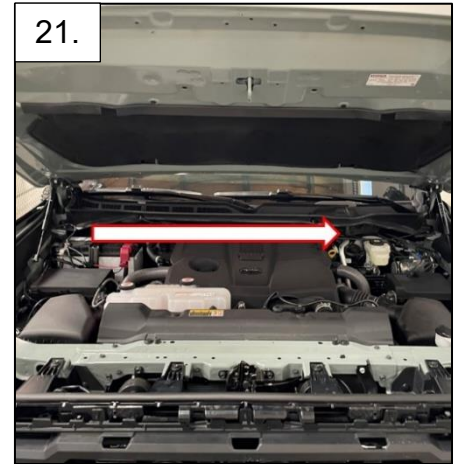

22. Select a location on the dash for the switch. Suggested locations are outlined in photo 22a. Check for clearance behind the switch panel and drill a 3/4" hole for the switch. To access behind this panel, remove the dash endcap by carefully prying from the bottom of the cap as shown in photo 22b. If desired, the switch mounting panel can be removed by carefully pulling in the arrowed direction.

23. Take a reference photo of the switch wiring. Disconnect the spade connectors and run the wires through the firewall and switch hole. Plug the switch back in and install it into the hole.

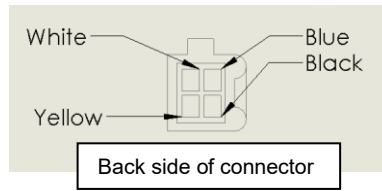
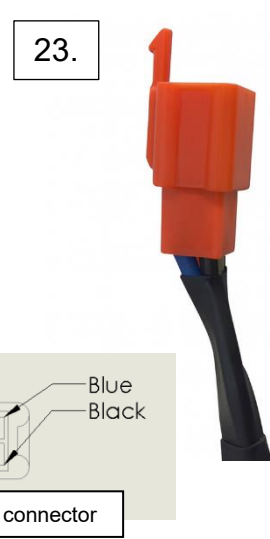

24. Reinstall the 4 - 10mm hex head bolts securing the top of the grill to the core support. Reinstall the 4 - 10mm hex head bolts securing the bottom of the bumper to the core support.

25. Reconnect the OEM electrical plugs along the top of the grill (arrowed).

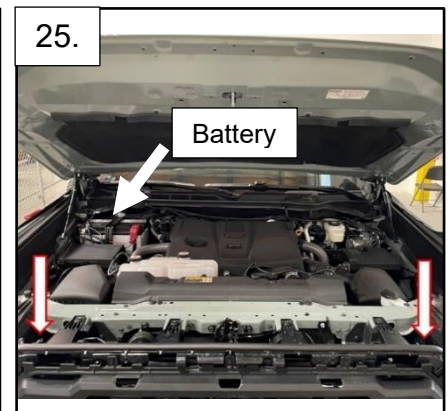
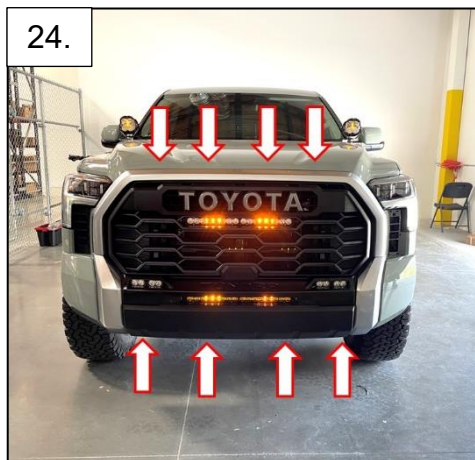

26. With some **patience**, reach into the inner fender and connect to a light power cord. Repeat for the passenger side taking care to make sure each harness is connected. (Image with grill removed for clarity.)

27. Using a 12mm socket, remove the negative battery cable. Connect the positive ring terminals to the positive battery wire. Repeat for the negative ring terminals to the negative battery wire and reconnect the negative cable. (For hybrid vehicles, follow steps H1 through H5 on the next page).

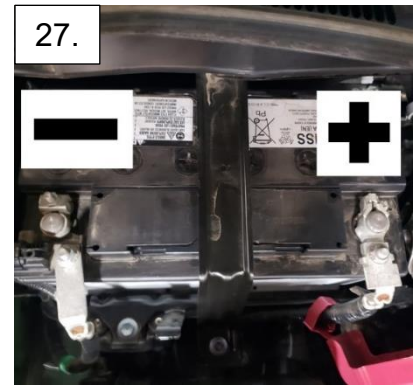
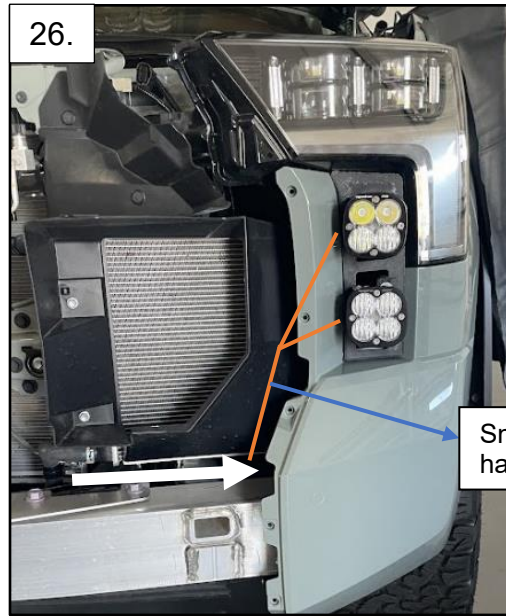

28. Operate the switch to confirm that each light is connected to the correct harness. Once the light connections are confirmed to be correct reinstall the driver side fender flare and secure using the 5 removed 10mm screws. Repeat on the passenger side of the vehicle.

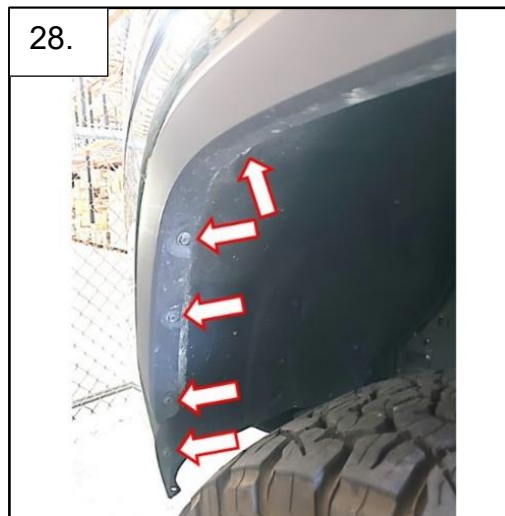

\*Tie all wires away from sharp, hot, and/or rotating components.

\* Re-torque all the fasteners after 100 miles.

\*Your install is now complete! Thank you for choosing Baja Designs.

## For hybrid vehicles only

H1. Remove the passenger side fuse panel cover and locate the positive battery wire and post (boxed).

H2. Using a 12mm socket, remove the nut holding down the wire and release the tab to the right of the post. (Make sure the wrench does not touch the high voltage system when loosening or tightening the nut.) Lift to remove the wire and plastic wire cover.

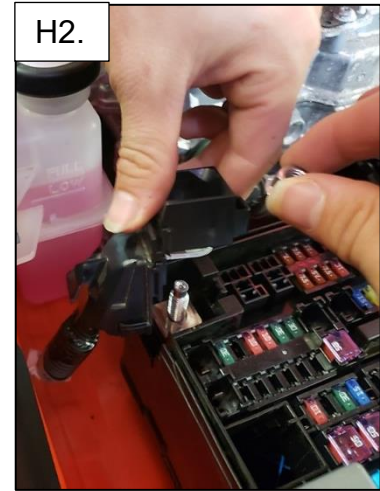

H3. Twist to pull apart the top of the plastic cable cover until it resembles photo H3. Using a flat head screwdriver, release the 2 tabs on the bottom of the plastic wire cover until the two halves separate and remove them from the wire. Discard the piece that the wire terminal runs through.

H4. Replace the battery cable and install the positive (red) ring terminal of the main wiring harness onto the post. Replace the upper battery cable cover and reinstall the 12mm nut and replace the fuse box cover.

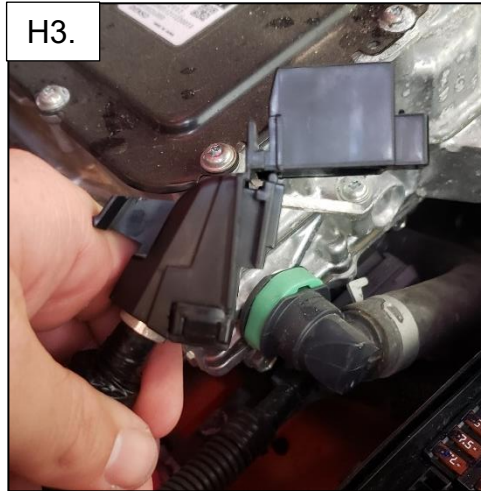

H5. Using a 10mm socket, remove the common ground bolt that the main harness relay is secured to and install the negative (black) ring terminal. Replace the ground bolt. Plug the S8 into the wiring harness and test the light.



\*Tie all wires away from sharp, hot, and/or rotating components.

\* Re-torque all the fasteners after 100 miles.

\*Your install is now complete! Thank you for choosing Baja Designs.

## Backlight add-on harness instructions for Squadron 2.0

**Note:** Included with this harness is four fuse taps. In the event that none will work for your application, a splice connector is included (shown on right).

1. Locate the fuse panel in the engine compartment. Remove cover.
2. Observe the inside of the fuse box cover, or the owner's manual to determine fuse locations and functions. The goal is to find a suitable circuit that is powered on when the vehicle is turned on. It is important to choose a fuse location that does not power sensitive electrical components, such as sensors and ignition modules. Choose a fuse that is activated by turning the key and remains active while the vehicle is starting and running. The IGN fuse is highly recommended for this. Using other circuits to run the backlight may result in the color changing when not desired.
3. Once the fuse location has been chosen, the multimeter or test light will be used to determine which side of the fuse is power and which side is the output. Using either tool, touch the positive test lead to one side of the fuse socket and touch the negative lead to the negative battery post, or any convenient ground. With the keys in the off position, neither side of the fuse socket should have power. If they do, another fuse location will need to be chosen.
4. Now, turn the keys to the on position and measure each side of the fuse socket. When the test light illuminates, or the multimeter DC voltage measures 12-14V, the power side of the fuse has been determined. Insert the fuse tap into the socket with the arrowed side blade (shown in image ii) contacting the power side. Plug in the backlight harness to the female bullet receptacle of the fuse tap. If the fuse socket originally had a fuse, place it into the open socket on the fuse tap.
5. Every fuse panel is different and sometimes there are adjacent components that make it difficult or impossible to plug in a fuse tap. In this case, the splice connector will need to be used. Find a wire that is powered when the keys are on. Ideally, this wire would power the daytime running lights and not an electrically sensitive component like a sensor. With the backlight harness inserted into the female bullet receptacle of the splice connector, clasp the splice over the desired power wire and clamp with pliers until an audible click is

### Tools Required

- Trim Tool
- Test Light, or Multimeter
- (Or Flathead Screwdriver)
- Scissors

i

- ATC -
- ATM -
- LP-Mini -
- Micro2 -

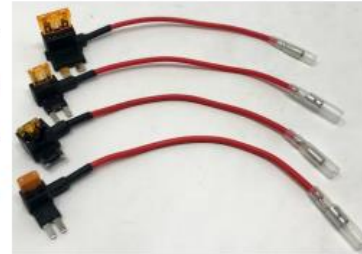

ii

Tap fuse  
OEM fuse

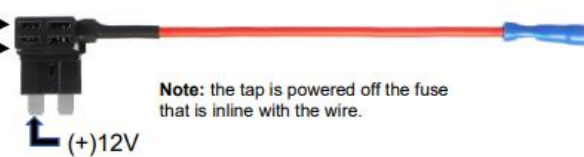

Note: the tap is powered off the fuse that is inline with the wire.

iii

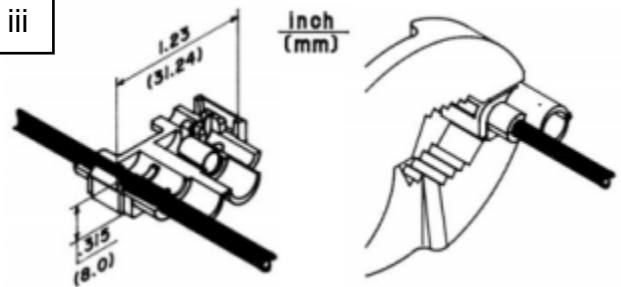

Fuse tap kit part #: 63-9209

## Backlight add-on harness instructions

6. Use the provided 5-amp fuse in the fuse tap for the backlight add-on harness (See image ii for reference).
7. Remove the Wedge lock from the plug by using a flat head screwdriver and **gently** prying along the edges with a flathead to release the lock (see image v for reference)
8. Locate the backlight add-on harness supplied in the kit. If a cavity plug was inserted previously in the PnP (Plug-n-Play) adapter, please remove it and insert the terminal inside the (3) pin location. (See image vii for reference)
9. To reinstall the wedge lock, simply push the wedge lock back in until it clicks in. (See image v for reference)
10. Determine the best routing for the backlight add-on harness.
11. Connect the bullet connector from the backlight add-on harness to the fuse tap and secure the wire harness. (Use image iii for reference)
12. Turn on the vehicle and test to see if the backlight function on the Squadron 2.0 works appropriately.
13. Use included zip ties to tie the harness out of the way of any hot and/or rotating components.

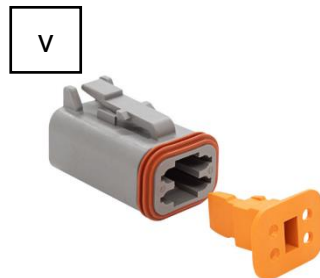
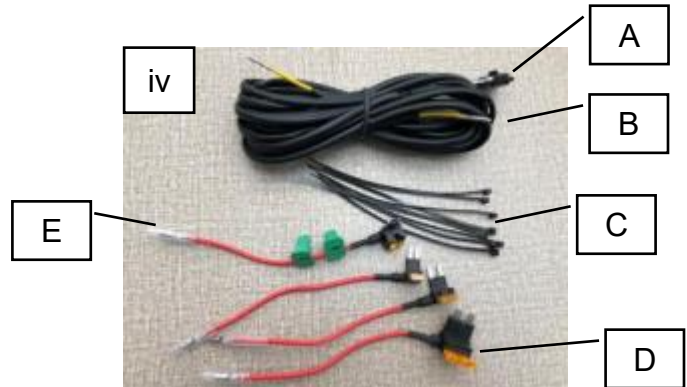

A: Splice connector  
B: Harness  
C: Zip ties  
D: Fuse taps  
E: Bullet connector

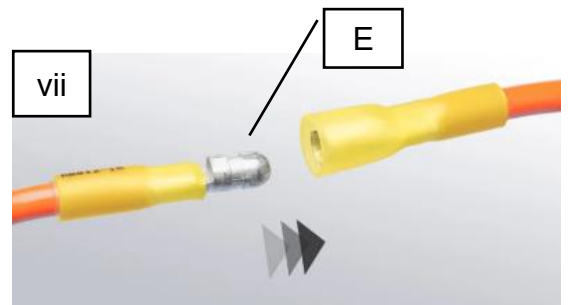
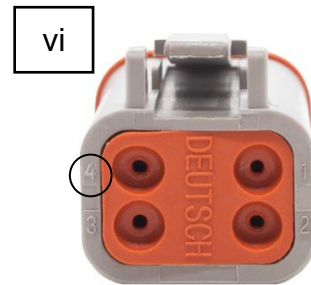

## Backlight switch adapter instructions

1. Connect the bullet connectors from the switch inline between the fuse tap and the backlight add-on harness.
2. Turn the switch on and off until the desired color is displayed as the backlight.
3. Once the desired color has been achieved, the switch can be either removed or left in. To remove the switch, turn the vehicle off and remove the switch. Reconnect the bullet connectors between the fuse tap and the backlight add-on harness. To leave the switch in line, secure the switch so it does not move. **Be sure to always leave switch in the “on” position if the switch will be left in.**



Inline switch part #: 60-0071